

# Symmetra™ PX

10–40 kW and 20 kW 208 V

## Operation

07/2014



# Legal Information

The Schneider Electric brand and any registered trademarks of Schneider Electric Industries SAS referred to in this guide are the sole property of Schneider Electric SA and its subsidiaries. They may not be used for any purpose without the owner's permission, given in writing. This guide and its content are protected, within the meaning of the French intellectual property code (Code de la propriété intellectuelle français, referred to hereafter as "the Code"), under the laws of copyright covering texts, drawings and models, as well as by trademark law. You agree not to reproduce, other than for your own personal, noncommercial use as defined in the Code, all or part of this guide on any medium whatsoever without Schneider Electric's permission, given in writing. You also agree not to establish any hypertext links to this guide or its content. Schneider Electric does not grant any right or license for the personal and noncommercial use of the guide or its content, except for a non-exclusive license to consult it on an "as is" basis, at your own risk. All other rights are reserved.

Electrical equipment should be installed, operated, serviced, and maintained only by qualified personnel. No responsibility is assumed by Schneider Electric for any consequences arising out of the use of this material.

As standards, specifications, and designs change from time to time, please ask for confirmation of the information given in this publication.

# Table of Contents

Important Safety Information .....	5
Safety Precautions .....	6
Overview .....	7
Display Interface.....	7
Overview Screen .....	7
Main Menu Screen.....	8
Navigating Through the Display Interface.....	8
Control Screen .....	9
Status Screens .....	9
Setup Screens.....	10
Accessories Screen .....	11
Logging Screen .....	12
Display Screen .....	12
Diags Screens .....	13
Help Screens.....	14
UPS Breaker Locations.....	14
Symmetra PX 10–40 cabinet .....	14
Symmetra PX 20 cabinet.....	14
Operation .....	16
Operation Procedures.....	16
Perform a Total Power Off.....	16
Turn Load ON/OFF .....	17
Transfer to Maintenance Bypass Operation.....	18
Return to Normal Operation from Maintenance Bypass Operation .....	19
System Restart (If Applicable).....	22
Communication Configuration .....	25
Network Management Card.....	25
Quick Configuration .....	25
Maintenance .....	27
Parts Replacement.....	27
Determine if You Need a Replacement Part .....	27
Replacement Parts .....	27
Replace a Power Module.....	28
Replace the Modular Batteries .....	29
Replace a Smart Slot Card .....	34
Troubleshooting .....	35
General Status .....	35
General Fault .....	37
Module Failure .....	38
Threshold Alarm.....	39
Bypass .....	39



# Important Safety Information

Read these instructions carefully and look at the equipment to become familiar with it before trying to install, operate, service or maintain it. The following safety messages may appear throughout this manual or on the equipment to warn of potential hazards or to call attention to information that clarifies or simplifies a procedure.



The addition of this symbol to a “Danger” or “Warning” safety message indicates that an electrical hazard exists which will result in personal injury if the instructions are not followed.



This is the safety alert symbol. It is used to alert you to potential personal injury hazards. Obey all safety messages with this symbol to avoid possible injury or death.

<b>⚠ DANGER</b>
<p><b>DANGER</b> indicates a hazardous situation which, if not avoided, <b>will result in death or serious injury.</b></p> <p><b>Failure to follow these instructions will result in death or serious injury.</b></p>
<b>⚠ WARNING</b>
<p><b>WARNING</b> indicates a hazardous situation which, if not avoided, <b>could result in death or serious injury.</b></p> <p><b>Failure to follow these instructions can result in death, serious injury, or equipment damage.</b></p>
<b>⚠ CAUTION</b>
<p><b>CAUTION</b> indicates a hazardous situation which, if not avoided, <b>could result in minor or moderate injury.</b></p> <p><b>Failure to follow these instructions can result in injury or equipment damage.</b></p>
<b>NOTICE</b>
<p><b>NOTICE</b> is used to address practices not related to physical injury. The safety alert symbol shall not be used with this type of safety message.</p> <p><b>Failure to follow these instructions can result in equipment damage.</b></p>

## Please Note

Electrical equipment should only be installed, operated, serviced, and maintained by qualified personnel. No responsibility is assumed by Schneider Electric for any consequences arising out of the use of this material.

A qualified person is one who has skills and knowledge related to the construction, installation, and operation of electrical equipment and has received safety training to recognize and avoid the hazards involved.

## Safety Precautions

### **⚠ DANGER**

#### **HAZARD OF ELECTRICAL SHOCK, EXPLOSION OR ARC FLASH**

All safety instructions in this document must be read, understood and followed.

**Failure to follow these instructions will result in death or serious injury.**

### **⚠ DANGER**

#### **HAZARD OF ELECTRICAL SHOCK, EXPLOSION OR ARC FLASH**

After the UPS system has been electrically wired, do not start up the system. Startup must only be performed by Schneider Electric.

**Failure to follow these instructions will result in death or serious injury.**

# Overview

## Display Interface

The display is the UPS user interface. It is used to configure and monitor the system and to set alarm thresholds. It also provides audible and visual alarms.

**NOTE:** The screens shown in this manual are examples only, and the use of XXX indicates variable data.

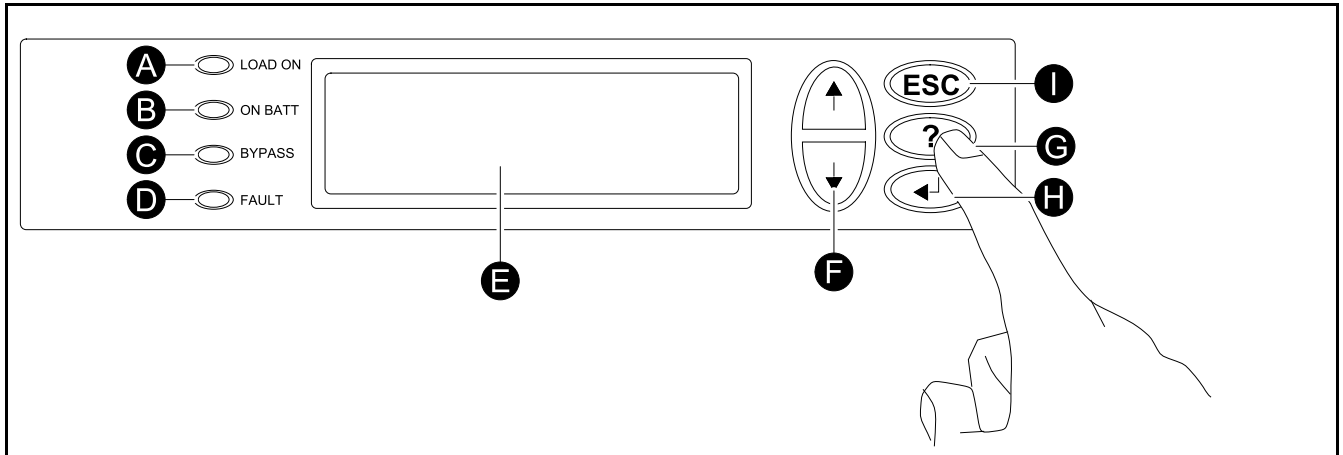

A	<b>LOAD ON LED</b>	When this LED is green, power to the load is on.
B	<b>ON BATT LED</b>	When the LED is yellow, the load is supplied through the batteries.
C	<b>BYPASS LED</b>	When this LED is yellow, the unit is in bypass.
D	<b>FAULT LED</b>	When this LED is red, there are one or more critical alarms in the system.
E	LCD screen	Displays alarms, status data, instructional help, and configuration items.
F	Arrow keys	Used to scroll through and select menu items.
G	Help key	Opens context-sensitive help.
H	Enter key	Opens menu items and confirms changes to the system parameters.
I	<b>ESC key</b>	Returns to the previous screen displayed.

## Overview Screen

1. The overview screen is the active screen when the display is not being operated. The overview screen provides basic system status information.

### Overview screen

```

Chrg 100%
Load 000%
XXXVin 000Vout XXHz
Runtime: 0hr 0m
    
```

## Main Menu Screen

1. When the overview screen is active, press the enter key to open the main menu screen. This screen is the launching pad to command, configure, and monitor the system.

### Main menu screen

→ Control	Logging
Status	Display
Setup	Diags
Accessories	Help

## Navigating Through the Display Interface

1. From the main menu the eight submenus shown on the illustration above can be opened. The menu structure is hierarchical and some submenus contain several screens. Press arrow buttons to navigate the selector arrow (→) to the desired submenu selection.

### Main menu screen

Control	Logging
→ Status	Display
Setup	Diags
Accessories	Help

2. Press the enter key to open the submenu. In the below example, the **Status** submenu has been opened. The arrow (↓) in the lower right corner indicates that the status submenu contains more screens. Press the down arrow button to view the other status screens.

### Status example screen

0	Vin	Vbyp	Vout
1	XXX.X	XXX.X	X.X
2	XXX.X	XXX.X	X.0
3	XXX.X	XXX.X	X.X ↓

3. Some screens contain changeable options, as indicated by an input arrow (↑). To change a setting, press the arrow buttons to increase or decrease its value. Press the enter key to accept the setting.

### Shutdown example screen

Low Batt Dur:	↑ 2 min
Shutdwn Dly:	20 sec
Return Dly:	0 sec
Return Bat Cap:	0%

### Shutdown example screen

Low Batt Dur:	↑ 10 min
Shutdwn Dly:	20 sec
Return Dly:	0 sec
Return Bat Cap:	0%



## Control Screen

### Main menu screen

→ Control	Logging
Status	Display
Setup	Diags
Accessories	Help

In the **Control** menu, the following items can be selected:

<b>UPS into Bypass</b>	Transfer to or return from maintenance bypass operation.
<b>Do Self Test</b>	Initiate a battery test.
<b>Simulate Power Fail</b>	Simulate a power failure.
<b>Graceful Reboot</b>	Turn off and start load equipment correctly.
<b>Graceful Turn Off</b>	Shut down load equipment correctly.
<b>Start Runtime Cal</b>	Begin runtime calibration of the UPS.
<b>Turn Load On/Off</b>	Apply power to or shut down the UPS.

## Status Screens

### Main menu screen

Control	Logging
→ Status	Display
Setup	Diags
Accessories	Help

The **Status** screens display information regarding load, battery, power module, voltage, and current.

<b>Status screen 1</b>	
Vin, Vout, Iout	The input voltage (V), output voltage (V), and output current (A) for each phase (1-3).
Vin, Vout, Vbyp	
<b>Status screen 2</b>	
%load assuming no redundancy	Percentage of the load in relation to the total capacity of all power modules.
<b>Status screen 3</b>	
%load allowing for n+ redundancy	Percentage of the load allowing for redundancy in your system.
<b>Status screen 4</b>	
Frequencies	The input and output frequency in hertz (Hz).
<b>Status screen 5</b>	
Batt Voltage	Actual voltage of the DC bus (volts). Percentage of battery capacity available. The available runtime for battery operation in hours and minutes. The number of installed battery modules. The number of failed battery modules.
Batt Capacity	
Runtime	
#Batts	
#Bad	

Status screen 6	
Capacity: kVA	The system load capacity.
Fault Tolerance	The configured redundancy for your UPS (n+0, n+1, n+2...).
Total Pwr Modules	The number of power modules installed.
Bad Pwr Modules	The number of failed power modules installed.
Status screen 7	
Alarm Thresholds	Settings configured for the thresholds that trigger alarms.
Fault Tolerance n+0	The alarm threshold for reduced redundancy.
Runtime hr min	The alarm threshold for reduced runtime.
load: kVA	Alarm indication of exceeded load.
Status screen 8	
Self Test	Status of the last self-test.
Lst Xfr	Information on the last transfer to battery operation.
Status	General UPS status.
IM	Status of the main intelligence module.
RIM	Status of the redundant intelligence module.

## Setup Screens

### Main menu screen

Control	Logging
Status	Display
→ Setup	Diags
Accessories	Help

From the **Setup** menu, the default factory settings can be changed:

<b>Shutdown</b>	<p>Configure the following system shutdown conditions:</p> <p><b>Low Batt Dur:</b> Low battery duration is the time from low battery signal to the shutdown of the load. This signal is sent to the server using shutdown software (PC + PCNS).</p> <p><b>Shutdwn Dly:</b> Shutdown delay is the time from when the UPS receives a shutdown command (usually sent by a server) to the shutdown of UPS power to the load equipment. This delay allows load equipment to finish shutdown processes.</p> <p><b>Return Dly:</b> Return delay is the amount of time the UPS needs to turn on after a power outage has ended.</p> <p><b>Return Bat Cap:</b> Return battery capacity is the minimum percentage of battery capacity required for the UPS to turn the load on.</p>
<b>Defaults</b>	Return all UPS settings to their default values.
<b>Output Frequency</b>	Set the desired output frequency.
<b>Alarms</b>	<p><b>Redundancy:</b> The state of redundancy that will trigger an alarm. Choices are:</p>

	<ul style="list-style-type: none"> <li>• N+0 – an alarm will occur when there is more load than all functioning power modules can support;</li> <li>• N+1 – an alarm will occur when there are no spare power modules in good condition;</li> <li>• N+2 – an alarm will occur if there are less than 2 spare power modules in good condition.</li> </ul> <p><b>Load:</b> When the load is greater than this threshold, an alarm will sound.</p> <p><b>Runtime:</b> When the UPS is on battery operation and the estimated remaining runtime is less than this threshold, an alarm will sound. This alarm is the result of an increase in load or a decrease in battery capacity.</p>
<b>Bypass</b>	Enables or disables the automatic transfer to bypass operation in case of overload or output fault, and bypass input voltage or frequency out of tolerance.
<b>Copy</b>	Copy the UPS settings.
<b>Other</b>	<p><b>Self Test:</b> Set the UPS to perform a self-test automatically at periodic intervals.</p> <p><b>UPS ID:</b> Type in a unique name for the UPS.</p> <p><b>Vout Reporting:</b> Set the reporting to the number of the tap to which the most significant load is wired on the output transformer.</p> <p><b>Output:</b> Set the UPS output voltage.</p> <p><b>BatFrAmpHour:</b> Set the Ampere-Hour rating of third party external battery cabinets.</p>

## Accessories Screen

### Main menu screen

Control	Logging
Status	Display
Setup	Diags
→ Accessories	Help

From the **Accessories** menu, the status of accessories connected to the UPS can be viewed.

**NOTE:** See relevant manuals for further information.

## Logging Screen

### Main menu screen

Control	→ Logging
Status	Display
Setup	Diags
Accessories	Help

The **Logging** menu allows to customize the UPS log. The following items are accessible from this screen:

<b>View Log</b>	Point to an entry in the log and press the enter key to view a description of the event. The display logs the most recent 64 events.
<b>View Statistics</b>	View statistics of the events logged.
<b>Configure Logging</b>	Set the type of events that are recorded in the log. To log a type of event, choose <b>On</b> .
<b>List Event Groups</b>	View the list of event types: <ul style="list-style-type: none"> <li>• Power Events</li> <li>• UPS Control Events</li> <li>• User Activities</li> <li>• UPS Fault Events</li> <li>• Measure UPS Events</li> </ul> For each group, press the enter key to display the individual events listed under the group.
<b>Clear Log</b>	Clear all events currently stored in the log.

## Display Screen

### Main menu screen

Control	Logging
Status	→ Display
Setup	Diags
Accessories	Help

The **Display** menu allows to customize the display interface. The following items are accessible from this screen:

<b>Date</b>	Set the correct date (day:month:year) and time (hour:minute).
<b>Password</b>	The password protects against unauthorized configuration changes.
<b>Information</b>	View the model number, serial number, date of manufacture, and revision number of the display interface.
<b>Beeper</b>	Configure the audible alarm interface: <ul style="list-style-type: none"> <li>• At UPS</li> <li>• At Disp</li> <li>• Vol</li> <li>• Click</li> </ul>

<b>Contrast</b>	Set the contrast on the LCD.
<b>Config</b>	Personalize the main menu. Choose each line you want displayed from a list of options. To change a line, move the selection arrow to the line you want to change and press the enter key. Scroll up or down the list to find the data you change and press the enter key. Scroll up or down the list to find the data you want displayed and press the enter key to save your changes. Press the <b>ESC</b> key to discard your changes.

## Diags Screens

### Main menu screen

Control	Logging
Status	Display
Setup	→ Diags
Accessories	Help

The **Diags** (diagnostics) menu provides information used in troubleshooting. The following items are accessible from this screen:

<b>Fault &amp; Diagnostics</b>	Lists any failures found.
<b>Frame Status</b>	If any status except ON or OK is displayed, an intelligence module, a power module, a card or a battery must be replaced. The <b>Faults &amp; Diagnostics</b> menu will describe the location of the failed module/ card. If no redundant intelligence module is installed, place the UPS in bypass operation before removing the intelligence module.
<b>Aux. Device Status</b>	Lists external device status.
<b>Comm Bus Status</b>	Gives information about the status (OK or not OK) of the different CAN communication buses.

## Frame Status

<b>Main Frame of x</b>		
<b>Rev, SN, Mfg Date</b>	Firmware revision Serial number Manufacturing date Hardware revision	
<b>Sub-Systems</b>	<b>Intelligence Module</b>	<b>Status:</b> xxx <b>Rev, SN, Mfg Date</b> (Revision, Serial number, Manufacturing Date) <b>Raw Status Data</b>
	<b>Redundant Intel Mod</b>	<b>Status:</b> xxx <b>Rev, SN, Mfg Date</b> (Revision, Serial number, Manufacturing Date) <b>Raw Status Data</b>
	<b>Power Modules</b>	Pwr Module x of x <b>Status:</b> xxx <b>Rev, SN, Mfg Date</b> (Revision, Serial number, Manufacturing Date) <b>Raw Status Data</b>

	<b>Sys Power Supplies</b>	System Pwr Supplies # 1: status # 2: status
<b>Raw Status Data</b>		

## Help Screens

To access the display interface context-sensitive help screens, press the ? key.

## UPS Breaker Locations

### Symmetra PX 10–40 cabinet

Breaker name	Breaker function	Breaker location
Q1	UPS input	In the wall-mounted maintenance bypass enclosure (option)
Q2	UPS output	
Q3	Maintenance bypass	

### Symmetra PX 20 cabinet

Breaker name	Breaker function	Breaker location (see illustration)
Q1	UPS input	A
Q2	UPS output	C
Q3	Maintenance bypass	B

Rear view of the PX 20 cabinet

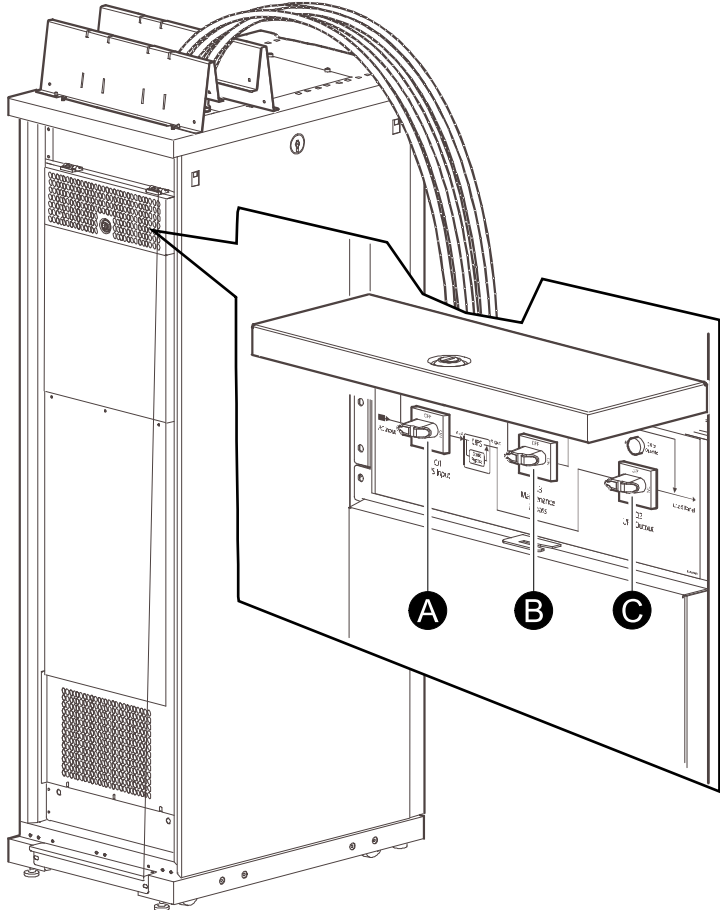

# Operation

## Operation Procedures

### Perform a Total Power Off

#### **NOTICE**

##### **HAZARD OF LOAD DROP**

This procedure will disconnect the load.

**Failure to follow these instructions can result in equipment damage.**

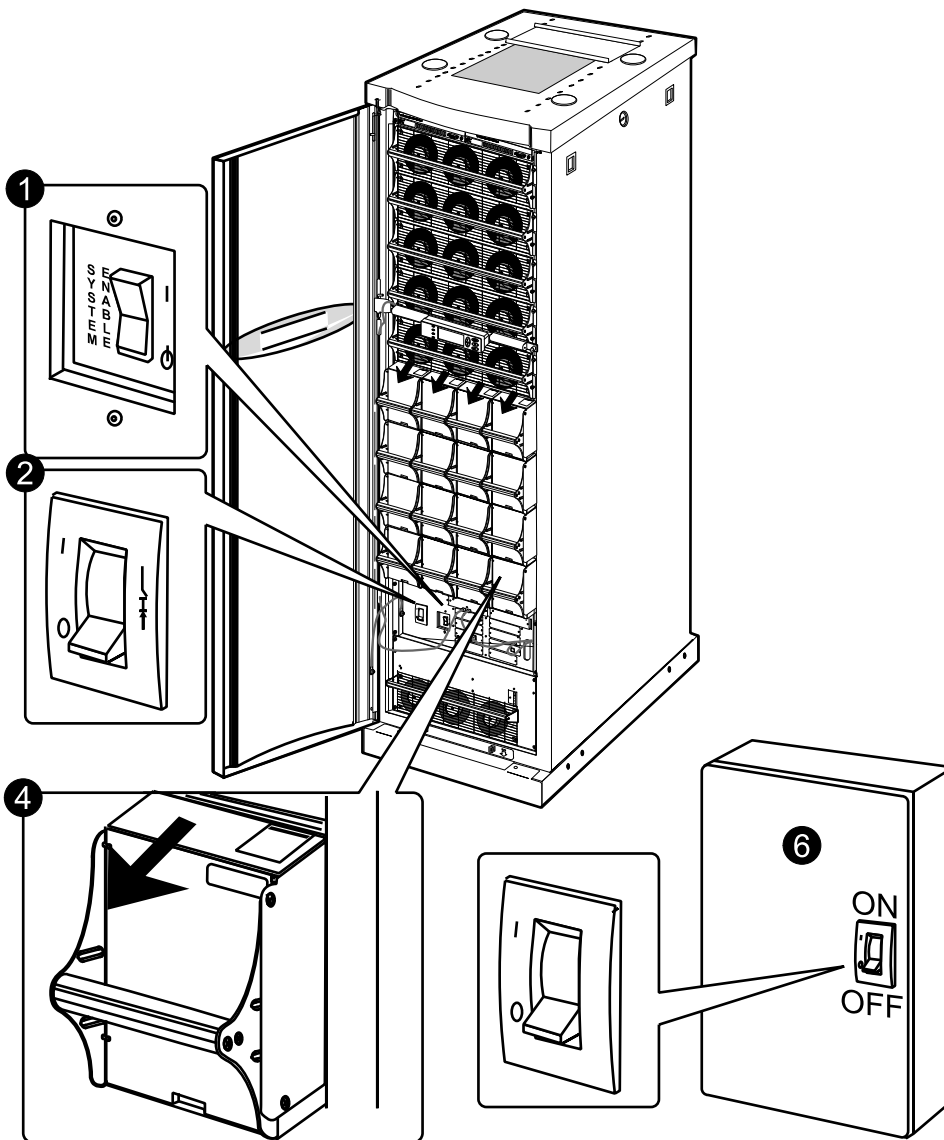

1. Set the system enable switch to the OFF position.



2. Set the DC disconnect breaker to the OFF position.

**Front view of UPS cabinet**

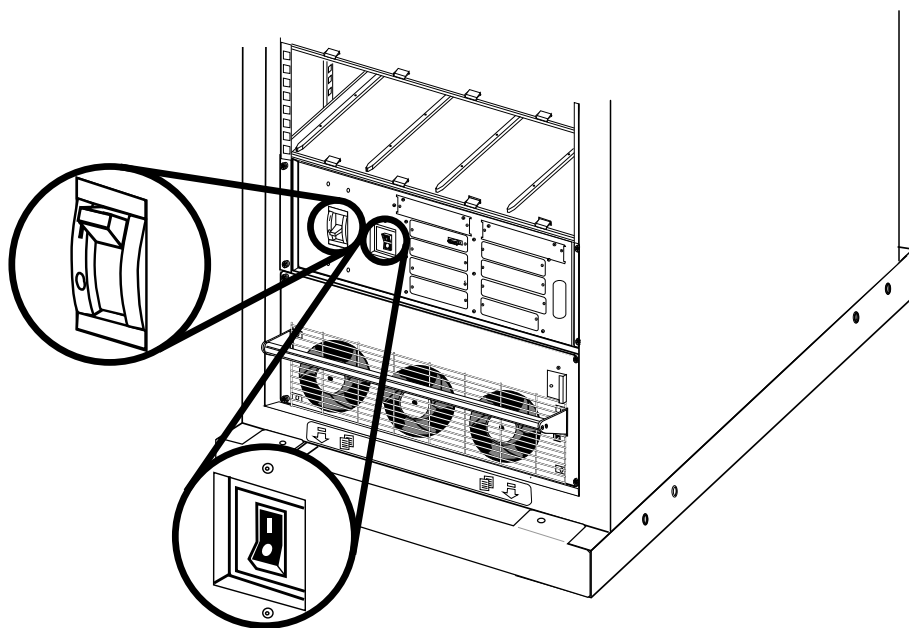

3. Set the DC disconnect breaker to the OFF position in the modular battery cabinets (if applicable).
4. Disconnect all battery units by removing or pulling out to the red disconnect line.
5. Set the Q1, Q2 and Q3 breakers (if present) to the OFF position.
6. Set the mains/utility power supply to the OFF or locked-out position. If the UPS has dual mains/utility supply, set both supplies to the OFF or locked-out position.

<b>NOTICE</b>
<b>HAZARD OF TILTING AND MODULAR BATTERY DAMAGE</b>
<p>To ensure that the cabinet does not tip, do not pull out the modular battery units beyond the red disconnect line. If you intend to completely remove the modular battery units, remove them from the cabinet one at a time. If you don't pull the modular battery units out to the red disconnect line, this could cause deep discharge/damage to the modular batteries.</p>
<b>Failure to follow these instructions can result in equipment damage.</b>

**Turn Load ON/OFF**

1. Select **Control** on the main menu and press the enter key.

**Main menu**

→ Control	Logging
Status	Display
Setup	Diags
Accessories	Help

2. Scroll to **Turn Load ON/OFF** and press the enter key.

**Control menu**

```
Graceful Reboot
Graceful Turn Off
Start Runtime Cal
→ Turn Load On ↑
```

The display will now show a message saying that the load has been turned ON/OFF.

```
UPS LOAD IS ON
```

## Transfer to Maintenance Bypass Operation

The UPS must be placed in maintenance bypass operation before it can be serviced. When the UPS is operating in maintenance bypass operation, power flows directly from the power supply through the maintenance bypass and to the load equipment.

1. Press the ESC key on the monitoring screen to open the main menu.
2. Select **Control** on the main menu and press the enter key.

**Main menu**

```
→ Control      Logging
Status        Display
Setup         Diags
Accessories   Help
```

3. Select **UPS into Bypass** and press the enter key.

**Control menu**

```
→ UPS Into Bypass
Do Self Test
Simulate Power Fail
Graceful Reboot ↓
```

4. Confirm the selection on the next screen: Select **Yes, UPS into Bypass** and press the enter key. The **BYPASS** LED will illuminate and the display will show the following two screens:

**NOTE:** The H3 LED above the Q3 breaker should then illuminate, indicating that it is safe to operate the Q3 breaker.

```
UPS has been
commanded to go
into Bypass
```

```
UPS load is in Bypass
Press any key....
```

5. Set the Q3 breaker to the ON position.

**NOTE:** The H2 LED above the Q2 Breaker should then illuminate, indicating that it is safe to operate the Q2 breaker.

6. Set the Q2 breaker to the OFF position.
7. Set the UPS system enable switch and the DC disconnect breaker to the OFF position.

#### Front view of UPS cabinet

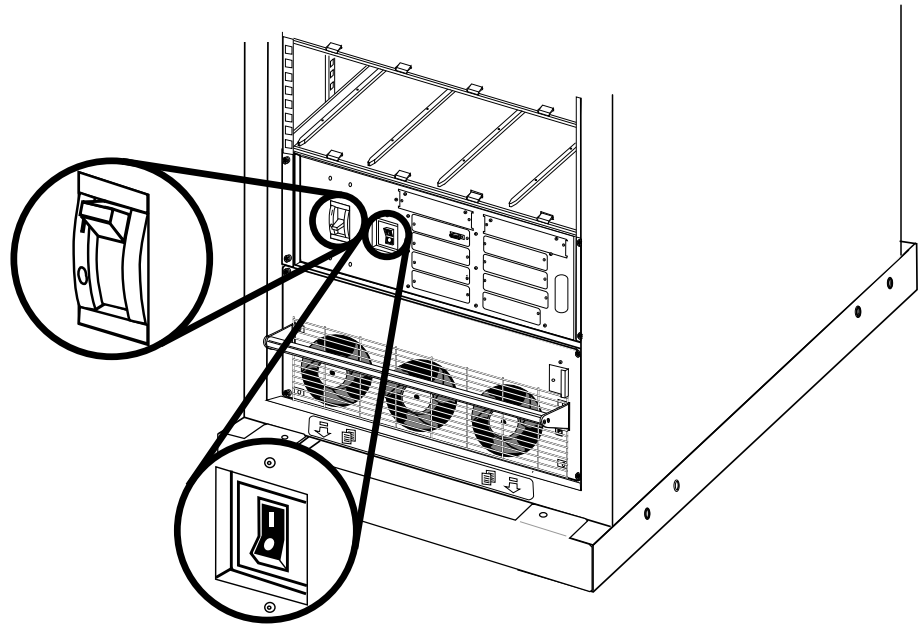

8. If applicable, set the modular battery cabinet DC disconnect breaker to the OFF position.

#### Front view of modular battery cabinet

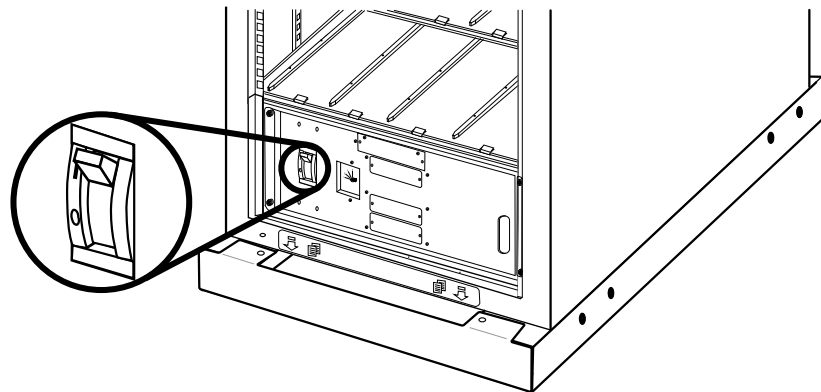

9. Set the Q1 breaker to the OFF position.

## Return to Normal Operation from Maintenance Bypass Operation

1. Set the Q1 breaker to the ON position.

- Set the UPS DC disconnect breaker and the system enable switch to the ON position.

#### Front view of UPS cabinet

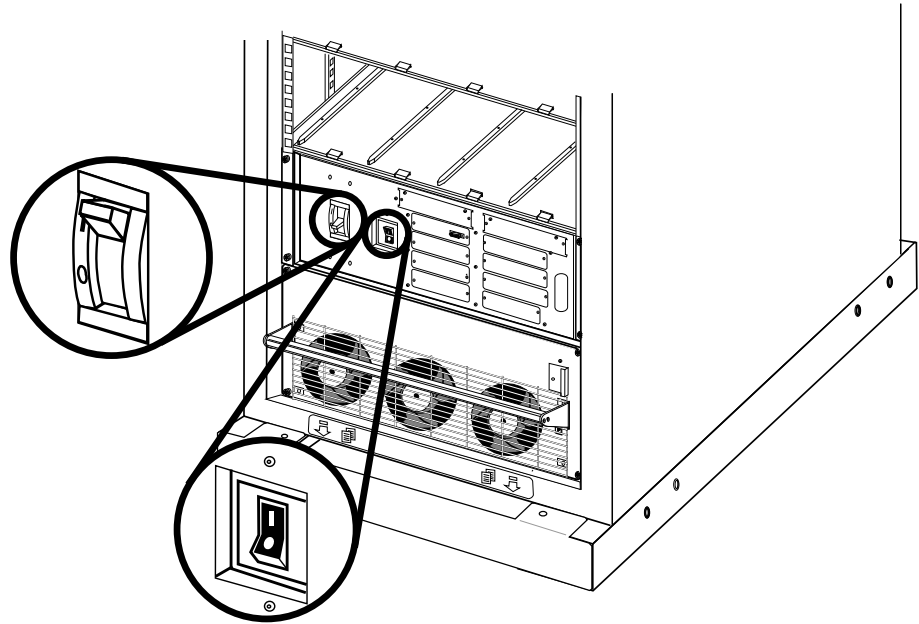

- Set the DC disconnect breaker for the modular battery cabinet (if applicable) to the ON position.

**NOTE:** Wait approximately 30 seconds for system to boot up. If the user interface displays a message saying that the number of power modules has decreased since last startup, check that all power module locking latches are engaged.

#### Front view of modular battery cabinet

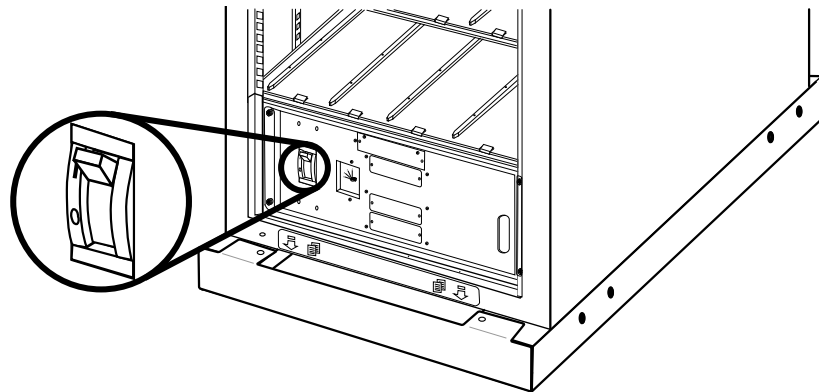

- On the display, press the **ESC** key until the main menu screen is displayed.

5. Select **Control>Turn UPS Output On**, and press the enter key.

#### Main menu

```
→ Control      Logging
Status         Display
Setup          Diags
Accessories    Help
```

#### Control menu

```
UPS Into Bypass
Do Self Test
Simulate Power Fail
Graceful Reboot ↓
```

```
Graceful Turn Off
Start Runtime Cal
→ Turn UPS Output On
```

6. On the prompt **Yes, UPS Output ON**, press the enter key to confirm.

```
Confirm
→ Yes, UPS Output On
No, Abort
```

The **LOAD ON** LED illuminates and the following two screens appear:

```
UPS has been
commanded to turn
load power on....
```

```
UPS load is on
Press any key....
```

7. On the display, press the **ESC** key until the main menu screen is displayed.  
8. Select **Control> UPS into Bypass**, and press the enter key.

#### Main menu

```
→ Control      Logging
Status         Display
Setup          Diags
Accessories    Help
```

#### Control menu

```
→UPS Into Bypass
Do Self Test
Simulate Power Fail
Graceful Reboot ↓
```

9. On the prompt **Yes, UPS into Bypass**, press the enter key to confirm.

```
Confirm
→ Yes, UPS into Bypass
No, Abort
```

**NOTE:** The H2 LED above the Q2 breaker should then illuminate, indicating that it is safe to operate the Q2 breaker.

10. Set the Q2 breaker to the ON position.

**NOTE:** The H3 LED above the Q3 breaker should then illuminate, indicating that it is safe to operate the Q3 breaker.

11. Set the Q3 breaker to the OFF position.
12. On the display, select **Control>UPS Out of Bypass** and press the enter key.
13. On the prompt **Yes, UPS Out of Bypass**, press the enter key to confirm.

```
Confirm
→ Yes, UPS Out
of Bypass
No, Abort
```

## System Restart (If Applicable)

**⚠ DANGER**

**HAZARD OF ELECTRICAL SHOCK, EXPLOSION, OR ARC FLASH**

Only Schneider Electric-trained personnel familiar with the construction and operation of the equipment, as well as the electrical and mechanical hazards involved, may install and remove system components

**Failure to follow these instructions will result in death or serious injury.**

System startup is included with your system. If moving the system to a new location and need a new startup, remove all batteries (see *Replace the Modular Batteries, page 29*), and power modules (see *Replace a Power Module, page 28*) and follow the total power off procedure (see *Perform a Total Power Off, page 16*). Raise the stabilizing feet before moving the cabinet and lower them after again moving the cabinet. When the system is reinstalled in its new location, follow applicable procedures below.

**NOTE:** During the transportation, installation or repositioning of the unit do not tilt the cabinet further than 45° from the vertical position.

### Restart the System

1. Set the mains/utility power to the ON position.

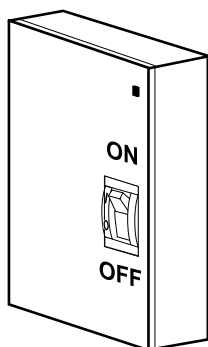

2. Set the Q1 and Q2 breakers (if present) to the ON position.

- Set the DC disconnect breaker in the modular battery cabinets (if applicable) to the ON position.

**Front view of modular battery cabinet**

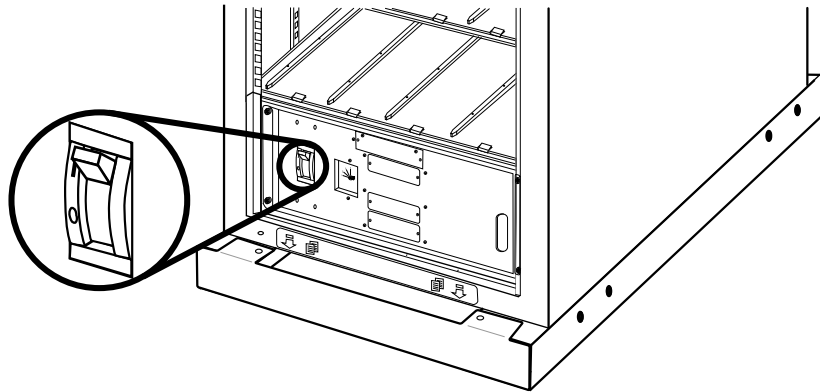

- Set the DC disconnect breaker to the ON position.

**Front view of UPS cabinet**

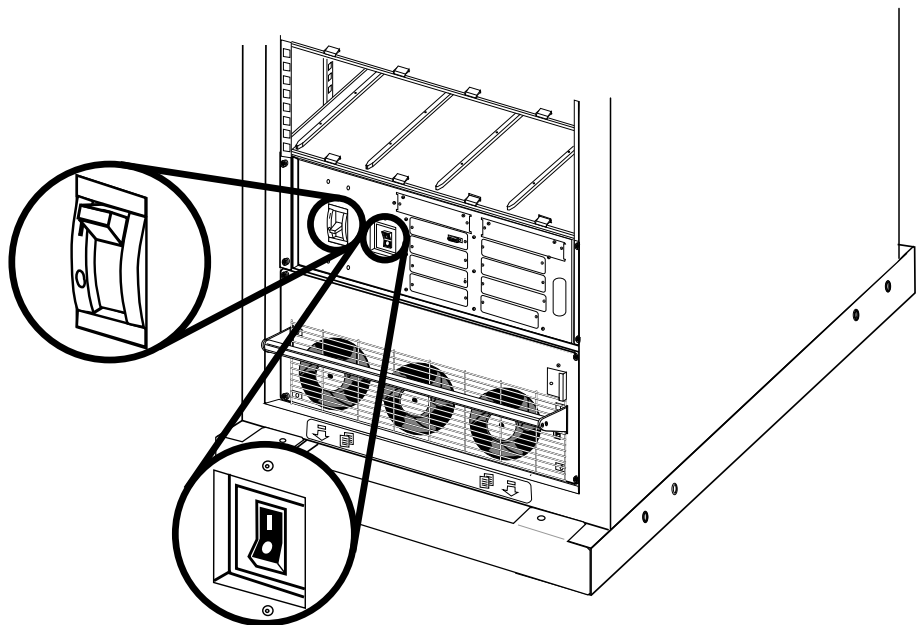

- Set the UPS system enable switch to the ON position.

**NOTE:** Wait approximately 30 seconds for the system to boot up. If the user interface displays a message saying that the number of power modules has decreased since last startup, check that all power module locking latches are engaged.

- Press the **ESC** key until you get to the main menu.
- Select **Status** and press the enter key. Verify that all power, battery, and intelligence modules are detected by the system and are functioning correctly.

**Main menu**

Control	Logging
→ Status	Display
Setup	Diags
Accessories	Help

**NOTE:** If a problem is reported, ensure that the system component in question is correctly installed. If the problem persists, refer to *Troubleshooting, page 35*.

- Press the **ESC** key until you get to the main menu.

9. Select **Control>Turn Load On** and press the enter key.

**Main menu**

→Control	Logging
Status	Display
Setup	Diags
Accessories	Help

**Control menu**

Graceful Reboot
Graceful Turn Off
Start Runtime Cal
→ Turn Load On ↑

10. On the message **The Load is ON**, press enter to confirm that the load is on.

→ UPS Load is ON
------------------

**NOTE:** The UPS is now ready to support the load equipment.

**NOTE:** If **ON BATT**, **FAULT**, or **BYPASS** is on, refer to *Troubleshooting*, page 35



# Communication Configuration

## Network Management Card

Front view of UPS cabinet

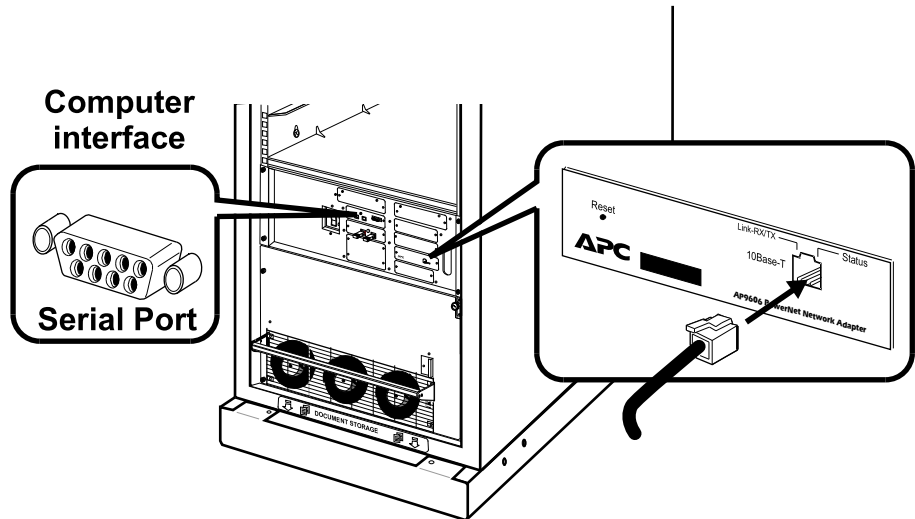

**NOTE:** The network cable is not supplied with the unit.

## Quick Configuration

**NOTE:** Disregard the procedures in this section if your system includes a StruxureWare Data Center Expert. See the documentation provided with the StruxureWare Data Center Expert for more information.

**NOTE:** The IP address, the subnet mask and the default gateway must be configured before the network management card can operate on a network.

From the display interface:

1. Press the **ESC** key to open the main menu.
2. Select **Accessories** and press the enter key.

```
Control          Logging
Status           Display
Setup            Diags
→ Accessories    Help
```

3. Select **Network Setup** and press the enter key.

```
Web/SNMP Mngmnt Card
→ Network Setup
View Network Setup
```

4. Select **IP** (IP address), **Mask** (subnet mask), and **Gway** (default gateway) by using the arrow keys and press the enter button to configure the chosen setting. Press the **ESC** key to cancel changes.

```
IP>>    XXX.XXX.XXX.XXX
Mask>>  XXX.XXX.XXX.XXX
Gway>>  XXX.XXX.XXX.XXX
Accept changes
```

5. Select **Accept changes** and press the enter key to finish and save your configuration.

```
IP>> 159.215.086
Mask>> 255.255.255.000
Gway>> 159.215.086.001
      → Accept changes
```

**NOTE:** If a default gateway is unavailable, use the IP address of a computer located on the same subnet as the network management card that is usually running. See network management card documentation for more information.

# Maintenance

## Parts Replacement

### Determine if You Need a Replacement Part

To determine if you need a replacement part, contact Schneider Electric Customer Support and follow the procedure below so that the Schneider Electric Customer Support representative can assist you promptly:

1. In the event of a module becoming inoperable, the display interface may show additional messages. Press any key to scroll through these message lists, record the information, and provide it to the representative.
2. Write down the serial number of the unit so that you will have it easily accessible when you contact Schneider Electric Customer Support.
3. If possible, call Schneider Electric Customer Support from a telephone that is within reach of the UPS display interface so that you can gather and report additional information to the representative.
4. Be prepared to provide a detailed description of the problem. A representative will help you solve the problem over the telephone, if possible, or will assign a Return Material Authorization (RMA) number to you. If a module is returned to Schneider Electric, this RMA number must be clearly printed on the outside of the package.
5. If the unit is within the warranty period, repairs or replacements will be performed free of charge. If it is not within the warranty period, there will be a charge.
6. If the unit is covered by an Schneider Electric service contract, have the contract available to provide information to the representative.

### Replacement Parts

Replacement part	Part number
40 kW cabinet <sup>1</sup>	SYCF40KF
20 kW cabinet <sup>1</sup>	0G-SY20KH
Modular battery cabinet <sup>2</sup>	SYCFXR8
10 kW power module <sup>3</sup>	SYPM10KF2
Battery module <sup>3</sup>	SYBT4
Battery unit <sup>3</sup>	SYBTU1-PLP
Intelligence module <sup>3</sup>	SYMIM4
Static switch module <sup>3</sup>	WSYXSW40KF
Network management card <sup>3</sup>	WAP9630CH
Display <sup>3</sup>	WAP9215RM
System power supply unit <sup>3</sup>	WSY2CSPS
Display and Computer Interface Card	WSYCDCI
Battery monitoring card	WSYCBTMON

1. Does not include power modules and batteries.
2. Does not include batteries
3. Included in the Spare Parts Kit for 40 kW (WSYFSUCF40KF-SPK)

Replacement part	Part number
Switch gear monitoring card	WSYCSGMON
System ID card	WSYCSYSID
Battery (XR) communication card	WSYCXRCOM
Spare Parts Kit for 40 kW	WSYFSUCF40KF-SPK

## Replace a Power Module

### ⚠ WARNING

#### HAZARD OF ELECTRIC SHOCK

Before replacing a power module, the UPS must be transferred into maintenance bypass operation.

**Failure to follow these instructions can result in death, serious injury, or equipment damage.**

### ⚠ CAUTION

#### HAZARD OF PERSONAL INJURY

Two persons are required for lifting a power module.

**Failure to follow these instructions can result in injury or equipment damage.**

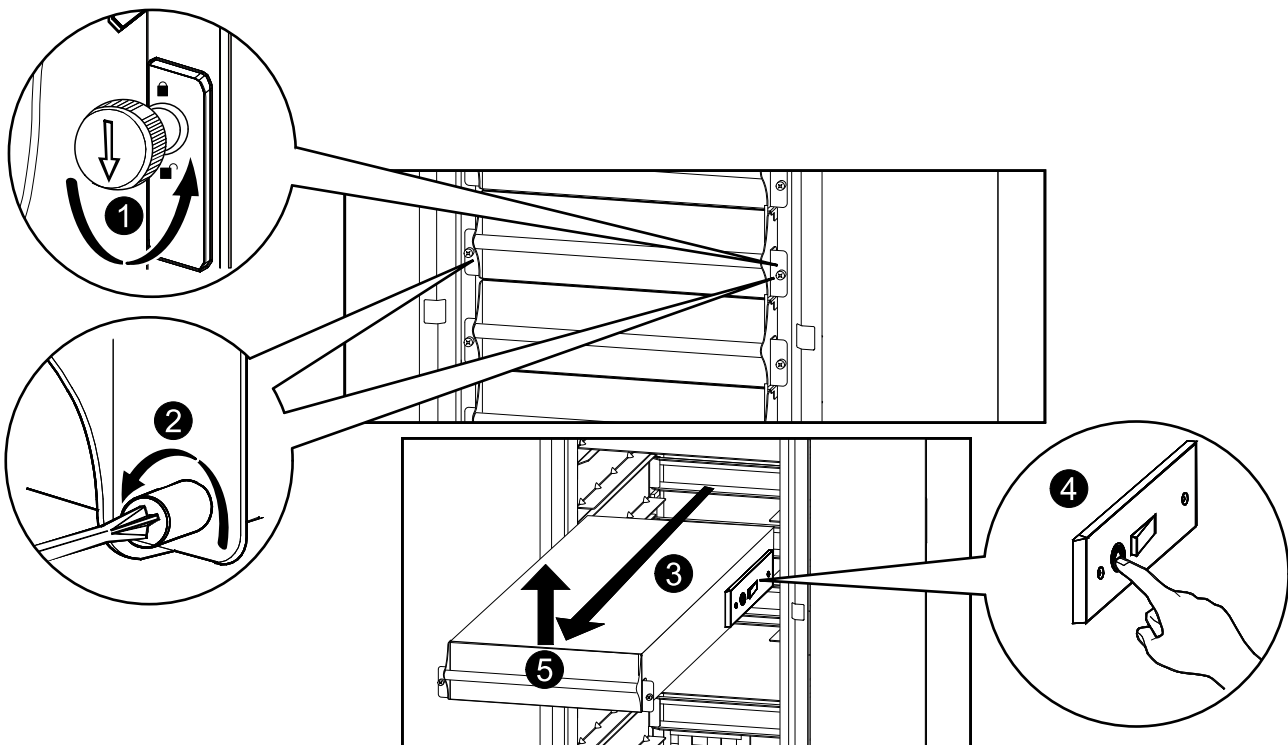

1. Turn the enable switch until the arrow points downwards.
2. Unscrew the spring-activated knobs on both sides of the module.
3. Pull the module up and out of the cabinet as far as the lock mechanism will allow.
4. Release the lock by pressing the black plastic tab on both sides of the module.

5. Pull the module out of the cabinet.
6. Push the replacement module securely into the cabinet.

### **⚠ CAUTION**

#### **HAZARD OF EQUIPMENT DAMAGE**

Do not attempt to insert the power module using excessive force, but make sure that it is in place before continuing.

**Failure to follow these instructions can result in injury or equipment damage.**

7. Tighten the spring-activated knobs on both sides of the module to ensure proper contact.
8. Secure the enable switch to start the power module.

### **⚠ CAUTION**

#### **HAZARD OF EQUIPMENT DAMAGE**

Tighten the spring-activated knobs before securing the enable switch to ensure that the module makes proper contact within the unit. The power module will not operate unless the enable switch is engaged. If it has not engaged, take out the power module and insert it again

**Failure to follow these instructions can result in injury or equipment damage.**

## **Replace the Modular Batteries**

### **⚠ DANGER**

#### **HAZARD OF ELECTRIC SHOCK, EXPLOSION OR ARC FLASH**

- Battery circuit breakers must be installed according to the specifications and requirements as defined by Schneider Electric.
- Servicing of batteries must only be performed or supervised by qualified personnel knowledgeable of batteries and the required precautions. Keep unqualified personnel away from batteries.
- Disconnect charging source prior to connecting or disconnecting battery terminals.
- Do not dispose of batteries in a fire as they can explode.
- Do not open, alter, or mutilate batteries. Released electrolyte is harmful to the skin and eyes. It may be toxic.

**Failure to follow these instructions will result in death or serious injury.**

**⚠ DANGER**

**HAZARD OF ELECTRIC SHOCK, EXPLOSION, OR ARC FLASH**

Batteries can present a risk of electric shock and high short-circuit current. The following precautions must be observed when working on batteries

- Remove watches, rings, or other metal objects.
- Use tools with insulated handles.
- Wear protective glasses, gloves and boots.
- Do not lay tools or metal parts on top of batteries.

**Failure to follow these instructions will result in death or serious injury.**

**⚠ WARNING**



**RISK OF EQUIPMENT DAMAGE**

- When replacing batteries, always replace with the same type and number of batteries or battery packs.
- Wait until the system is ready to be powered up before installing batteries in the system. The time duration from battery installation until the UPS system is powered up must not exceed 72 hours or 3 days.
- Batteries must not be stored more than six months due to the requirement of recharging. If the UPS system remains de-energized for a long period, we recommend that you energize the UPS system for a period of 24 hours at least once every month. This charges the batteries, thus avoiding irreversible damage.

**Failure to follow these instructions can result in death, serious injury, or equipment damage.**

**Storage of the modular battery modules:**

The modular battery modules must be stored indoors and with their protective packaging still in place.

		
Ambient temperature: -15 to 40 °C (5 to 104 °F)	Relative humidity: 25–85% Non-condensing	Store in a place free from: vibration, dust, direct sunlight, and moisture

Stored modular batteries must be recharged at regular intervals depending on the storage temperature:

Storage temperature	Recharge interval
-15 °C to 20 °C (5 °F to 68 °F)	9 months
20 °C to 30 °C (68 °F to 86 °F)	6 months
30 °C to 40 °C (86 °F to 104 °F)	3 months

**▲ CAUTION****HAZARD OF PERSONAL INJURY**

Two persons are required for lifting a modular battery module.

**Failure to follow these instructions can result in injury or equipment damage.**

**NOTE:** When removing the batteries, start from the highest available bay.

1.

- a. **For 200 V versions only:** Remove the battery compartment cover by loosening the six screws and set aside for later use.

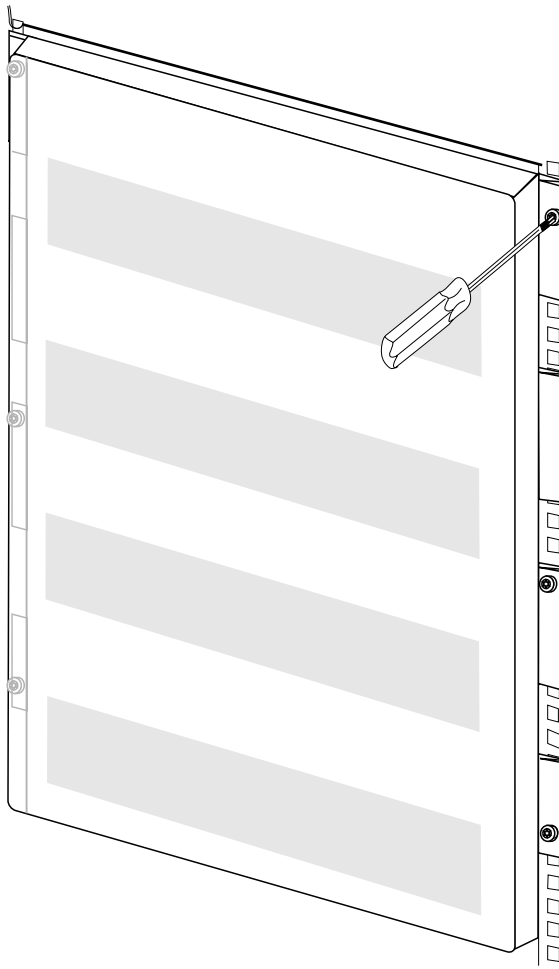

- b. **For 200 V versions only:** Remove the three screws in the battery securing bracket, push it to the left and remove. Set aside for later use.

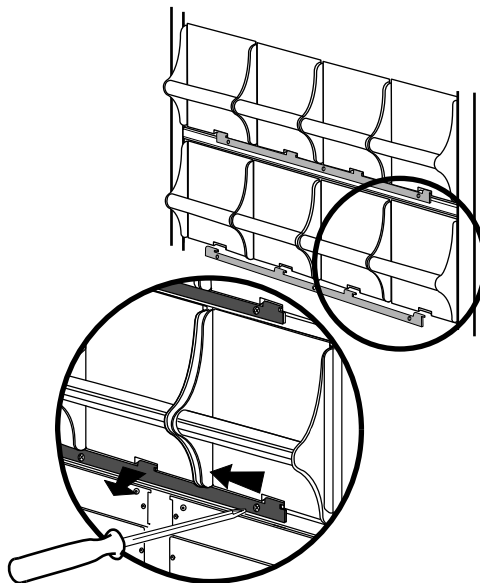

- c. Holding the handle, gently lift the modular battery unit and pull it halfway out. A locking mechanism prevents the modular battery unit from being pulled all the way out.



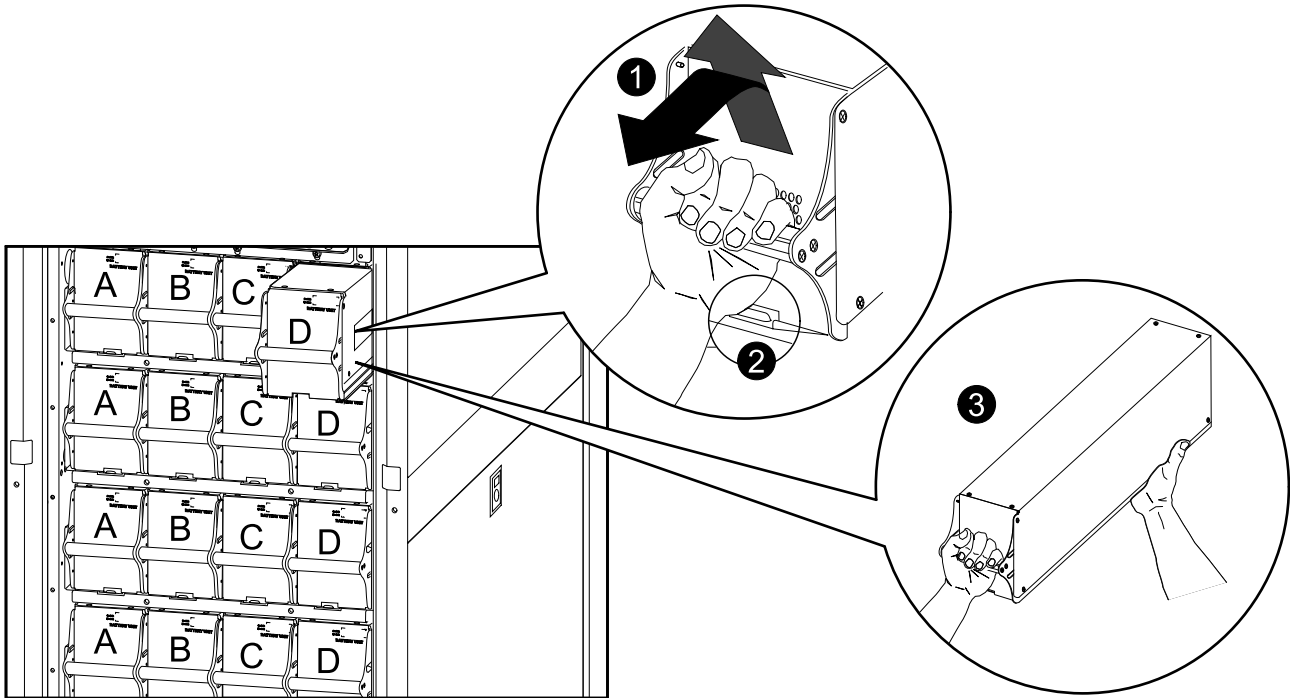

2. Release the locking mechanism by lifting the modular battery unit. Pull the modular battery unit completely out while supporting it.
3. Take the replacement modular battery unit and push it into the system.

**NOTE:** When installing the batteries, start from the lowest available bay.

**NOTE:** When replacing modular batteries, always replace both modular batteries A+B or C+D (see illustration above) as they are interconnected in pairs.

For four modular batteries in a row it is recommended to replace all four at the same time to ensure optimal run-time (Example 1). The modular batteries can also be replaced in twos, but always A+B (Example 2) or C+D (Example 3).

Four modular batteries in a row				
	Column A	Column B	Column C	Column D
Example 1 – Recommended	New	New	New	New
Example 2 – Minimum requirement	New	New	Old	Old
Example 3 – Minimum requirement	Old	Old	New	New

**NOTE:** Allow modular batteries a 24-hour recharging period after system startup/modular battery replacement for modular battery monitoring data to become fully reliable.

4. The display interface will show a message saying that it has registered a new battery.

5. **For 200 V versions only:** Attach the battery securing bracket and fasten with 3 screws, and reattach the battery compartment cover and fasten with the 6 screws.

**NOTE:** Allow modular batteries a 24-hour recharging period after system startup/modular battery replacement for modular battery monitoring data to become fully reliable.

<b>▲ CAUTION</b>
<b>RISK OF EQUIPMENT DAMAGE</b>
<ul style="list-style-type: none"> <li>• Wait until the system is ready to be powered up before installing batteries in the system. The time duration from battery installation until the UPS system is powered up must not exceed 72 hours or 3 days.</li> </ul>
<b>Failure to follow these instructions can result in injury or equipment damage.</b>

## Replace a Smart Slot Card

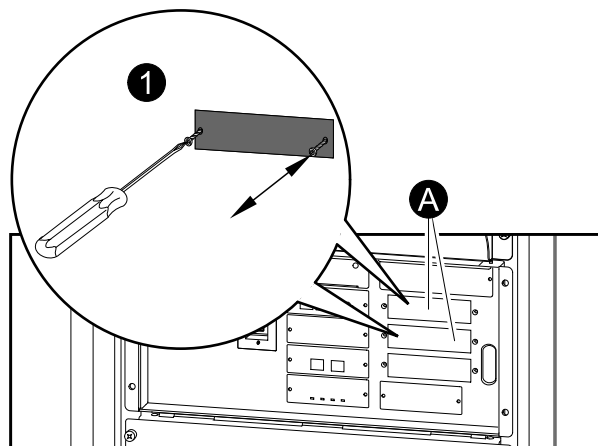

A. Only the cards in these two locations can be replaced.

1. Loosen the two screws on the sides of the card and carefully pull it out of the cabinet.
2. Install the new card and secure it with the two screws.

**NOTE:** The UPS has an embedded network management card.

# Troubleshooting

This section lists all of the common alarm and status messages that might be displayed on the UPS display interface. A suggested corrective action is listed with each message to help troubleshoot the problem.

**NOTE:** If a problem is reported, ensure that the system component in question is correctly installed.

## General Status

Display message	Description	Corrective action
Input Freq outside configured range	The input frequency to the UPS is outside the configured range. The output frequency will not synchronize with the input frequency. Normal bypass is not available.	<b>Option 1:</b> Improve the frequency of the incoming voltage. <b>Option 2:</b> Widen range of the acceptable incoming frequency using the display interface. Select Startup, Setup, Output, Freq Select. <b>Option 3:</b> Proceed with startup.
AC adequate for UPS but not for bypass	The UPS will function online with the input voltage, but the input voltage is not adequate to power the load in the event of bypass operation.	<b>Option 1:</b> Improve the incoming voltage. <b>Option 2:</b> Proceed with startup. Normal bypass is not available.
Low/No AC input, startup on battery	Input voltage is not adequate to start the UPS. If startup proceeds, the UPS will function in battery operation.	<b>Option 1:</b> Cancel startup until acceptable input voltage is present. <b>Option 2:</b> Continue startup and run on battery.
Main Intelligence Module inserted	An intelligence module has been installed in the UPS.	No corrective action necessary.
Main Intelligence Module removed	An intelligence module has been removed from the UPS.	If no intelligence modules have been removed, check that the intelligence modules are properly inserted and that the fastening screws are tight.
Redundant Intelligence Module inserted	An intelligence module has been installed in the UPS.	No corrective action necessary.
Redundant Intelligence Module removed	An intelligence module has been removed from the UPS.	If no intelligence modules have been removed, check that the intelligence modules are properly inserted and that the fastening screws are tight.
# Batteries changed since last ON	At least one battery module has been added or removed from the UPS since the last time the power on command was used.	No corrective action necessary.
# Pwr modules changed since last ON	At least one power module has been added or removed from the UPS since the last time the power on command was used.	Check that all power modules are properly inserted, the two fastening screws are tight, and the locking latches are engaged.
Battery Module Quantity increased	At least one battery module has been added to the system.	No corrective action necessary.
Battery Module Quantity decreased	At least one battery module has been removed from the system.	If no battery modules have been removed, ensure that all battery units are properly inserted.

Display message	Description	Corrective action
Power Module Quantity increased	At least one power module has been added to the system	No corrective action necessary.
Power Module Quantity decreased	At least one power module has been removed from the system.	If no power modules have been removed, check that all power modules are properly inserted, the two fastening screws are tight, and the locking latch is engaged.
Battery Cabinet Quantity increased	At least one external battery cabinet has been connected to the UPS.	No corrective action necessary.
Battery Cabinet Quantity decreased	At least one external battery cabinet has been disconnected from the UPS.	Ensure that all battery cabinet communication cables are properly connected and that the LEDs are illuminated on the battery monitor boards..
Low-Battery	The UPS is online and the battery charge is low.	No corrective action necessary. <b>NOTE:</b> If the input voltage fails, runtime will be limited.
Battery Discharged	The UPS is in battery operation and the battery charge is low.	No corrective action necessary. <b>NOTE:</b> Runtime is limited in duration. Shut down the system and the load equipment or restore incoming voltage.
Automatic Self Test	The UPS has started pre-programmed battery test.	No corrective action necessary.
Number of System Power Supplies Decreased	One of the system power supplies has been removed.	If no system power supplies have been removed, check that they have been properly inserted.
External switch gear Q001 closed	The external switch gear Q001 is closed.	No corrective action necessary.
External switch gear Q001 opened	The external switch gear Q001 is open.	No corrective action necessary. The UPS is disconnected from the input power.
External switch gear Q002 closed	The external switch gear Q002 is closed.	No corrective action necessary.
External switch gear Q002 opened	The external switch gear Q002 is open.	No corrective action necessary. The load is disconnected from the UPS output.
External switch gear Q003 closed	The external switch gear Q003 is closed.	No corrective action necessary. The UPS is in maintenance bypass operation.
External switch gear Q003 opened	The external switch gear Q003 is open.	No corrective action necessary.
Graceful Shutdown	A graceful shutdown or reboot has been initiated from the display interface or other accessory.	No corrective action necessary.
Redundancy OK	A loss of power module redundancy occurred and the redundancy has been restored. Either additional modules have been installed or the load has been reduced.	No corrective action necessary.

## General Fault

Display Message	Description	Corrective Action
Replace Batt(s)	One or more battery units need replacement	Refer to <i>Parts Replacement</i> , page 27 for procedures.
The Redundant Intelligence Module Has Assumed Control	The main intelligence module has failed, and the redundant intelligence module is functioning as the primary intelligence module.	Replace the main intelligence module. Refer to <i>Parts Replacement</i> , page 27 for procedures.
On Battery	The UPS has transferred to battery operation as the input is not within the acceptable range. The batteries continue to discharge until the input is restored to an acceptable range.	No corrective action necessary. <b>NOTE:</b> Runtime is limited in duration. Prepare to shut down the UPS and the load equipment or restore incoming voltage.
Load Shutdown From Bypass. Input Freq/Volts Out Of Range	The UPS was on bypass and had to turn the output off because the input was out of acceptable range	Correct the input voltage problem.
Internal Temperature Exceeded Upper Limit	The temperature of one or more battery units has exceeded system specifications.	Ensure that the ambient temperature meets the specifications of the system. If the ambient temperature is below 40 °C (104 °F), initiate a self-test to detect any bad battery units. Replace bad battery units.
Shutdown Due To Low Battery	The UPS was in battery operation and shut down the load when no more battery power was available.	No corrective action necessary.
No Batteries Are Connected	No battery power is available.	<b>Option 1:</b> Check that batteries are inserted properly. <b>Option 2:</b> Check for DC breaker trip.
UPS Is Overloaded	The load exceeded the system power capacity.	<b>Option 1:</b> Decrease the load. <b>Option 2:</b> If possible, add a power module to the system.
Internal Communications Failed	One of the buses used for the communication between the UPS modules failed.	Contact Schneider Electric Customer Support.
No Working Power Modules Found	No working power modules were found.	<b>Option 1:</b> Check that all power modules are properly inserted, the two fastening screws are tight, and the locking latches are engaged. <b>Option 2:</b> Check for other alarm messages.
XR Frame Fault	One of the battery cabinets has failed.	Contact Schneider Electric Customer Support.
System Not Synchronized to AC Line	System cannot synchronize to AC line and bypass mode may not be available if required.	<b>Option 1:</b> Decrease the sensitivity to input frequency (select Startup, Setup, Output Freq, and select value). <b>Option 2:</b> Correct the input voltage to provide acceptable voltage on frequency.
Battery Voltage Is Too High	The battery voltage is too high and the charger has been deactivated.	Contact Schneider Electric Customer Support.
Site Wiring Fault	Wrong phase rotation on the input side.	An electrician should check that the UPS has been wired properly.

Display Message	Description	Corrective Action
Isolation Transformer Over-temperature	The isolation transformer temperature is too high.	Contact Schneider Electric Customer Support.
External DC Disconnect Switch Tripped	The external DC disconnect switch tripped. Battery power is not available or the runtime is lower than expected.	Activate the external DC Disconnect Switch.
Sys Power Sply Fail	A system power supply has failed. One of the power supplies has to be changed.	Contact Schneider Electric Customer Support.
Battmon Card Failed	The battery monitor card has failed.	Refer to <i>Parts Replacement, page 27</i> for further details.
Battery Monitor Card Removed	The battery monitor card has been removed.	If the battery monitor card has not been removed, check that it has been properly inserted.
SwGr Comm Card Fail	The switch gear communications card has failed.	Refer to <i>Parts Replacement, page 27</i> for further details.
Switch Gear Communication Card Removed	The switch gear communications card has been removed.	If the switch gear communication card has not been removed, check that it has been properly inserted.
Internal DC Disconnect Switch Tripped	The internal DC disconnect switch tripped and battery power is not available.	Activate the internal DC Disconnect Switch.
Static Bypass Switch Module Fault	The static bypass switch module has failed.	Contact Schneider Electric Customer Support.
System ID Card Removed	The system ID card has been removed.	If the system ID card has not been removed, check that it has been properly inserted.
System ID Card Failed	The system ID card has failed.	Refer to <i>Parts Replacement, page 27</i> for further details.
System Start Up Configuration Failed	System configuration download failed. Unable to determine system voltage and/or cabinet size.	Check for other alarms and contact Schneider Electric customer support if problem persists.

## Module Failure

Display message	Description	Corrective action
Battery Module Fault	A battery module has failed and requires replacement.	Replace the battery module. Refer to <i>Parts Replacement, page 27</i> for procedures.
Power Module Fault	A power module has failed and requires replacement.	Replace the power module. Refer to <i>Parts Replacement, page 27</i> for procedures.
Intelligence Module Fault	The main intelligence module has failed and requires replacement.	Replace the main intelligence module. Refer to <i>Parts Replacement, page 27</i> for procedures.
Redundant Intelligence Module Fault	The redundant intelligence module has failed and requires replacement.	Replace the redundant intelligence module. Refer to <i>Parts Replacement, page 27</i> for procedures.

## Threshold Alarm

Display message	Description	Corrective action
Redundancy Has Been Lost	The UPS no longer detects redundant power modules. One or more power module(s) have failed, or the load has increased.	<b>Option 1:</b> If possible, install additional power modules. <b>Option 2:</b> Replace failed modules. Refer to <i>Parts Replacement</i> , page 27 for procedures. <b>Option 3:</b> Reduce the load.
Redundancy Is Below Alarm Limit	Actual power module redundancy has fallen below user-specified redundancy alarm threshold. At least one power module has failed or the load increased.	<b>Option 1:</b> If possible, install additional power modules. <b>Option 2:</b> Replace failed modules. Refer to <i>Parts Replacement</i> , page 27 for procedures. <b>Option 3:</b> Reduce the load. <b>Option 4:</b> Use display interface to change alarm limit.
Runtime Is Below Alarm Threshold	The predicted runtime is lower than the user-specified minimum runtime alarm threshold. Either the battery capacity has decreased, or the load has increased.	<b>Option 1:</b> Allow the battery modules to recharge. <b>Option 2:</b> If possible, increase the number of battery modules. <b>Option 3:</b> Reduce load. <b>Option 4:</b> Decrease alarm threshold.
Load Power Is Above Alarm Limit	The load has exceeded the user-specified load alarm threshold.	<b>Option 1:</b> Use the display interface to raise the alarm threshold. <b>Option 2:</b> Reduce the load.
Load Is No Longer Above Alarm Threshold	The load exceeded the alarm threshold and the situation has been corrected either because the load decreased or the threshold was increased.	No corrective action necessary
Min Runtime Restored	The system runtime dropped below the configured minimum and has been restored. Additional battery modules were installed, the existing battery modules were recharged, the load was reduced, or the threshold was decreased.	No corrective action necessary.

## Bypass

Display message	Description	Corrective action
Bypass Not Available Input Freq/ Volt Out Of Range	The frequency or voltage is out of acceptable range for bypass. This message occurs when the UPS is online, and indicates that the bypass mode may not be available if required.	Correct the input voltage to provide acceptable voltage or frequency.
UPS In Bypass Due To Fault	The UPS has transferred to Bypass Mode because a fault has occurred.	Contact Schneider Electric Customer Support.
UPS In Bypass Due To Overload	The load exceeded the system power capacity. The UPS has switched to Bypass Mode.	<b>Option 1:</b> Decrease the load. <b>Option 2:</b> If possible, add a power module to the system.

<b>Display message</b>	<b>Description</b>	<b>Corrective action</b>
UPS In Maintenance Bypass	The system is in maintenance bypass: Q002 is open and Q003 is closed.	No corrective action necessary.
UPS In Forced Bypass	The system has been forced into maintenance bypass operation: Q003 is closed and/or manual bypass switch is activated.	No corrective action necessary.
Static Bypass Switch Module Removed	The static bypass switch has been removed.	If a static bypass switch has not been removed, check that it has been properly inserted.

If the system works in bypass, ensure the presence of AC mains supply input.

If a problem persists, note UPS model number, serial number, and date purchased before calling Schneider Electric Customer Support.









Schneider Electric  
35 rue Joseph Monier  
92500 Rueil Malmaison  
France

+ 33 (0) 1 41 29 70 00  
[www.schneider-electric.com](http://www.schneider-electric.com)

As standards, specifications, and design change from time to time, please ask for confirmation of the information given in this publication.

© 2012 – 2014 Schneider Electric. All rights reserved.  
990-4147E-001